

FOR REFERENCE ONLY - NOT PROJECT SPECIFIC

Example 1: Single actuator operation

**AC Actuator**

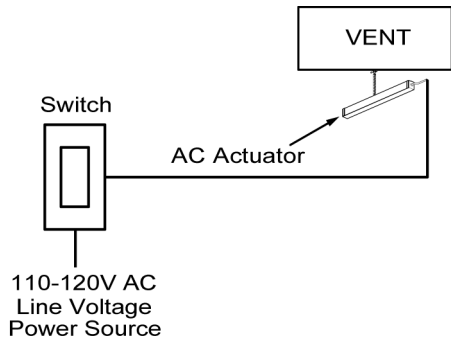

**DC Actuator**

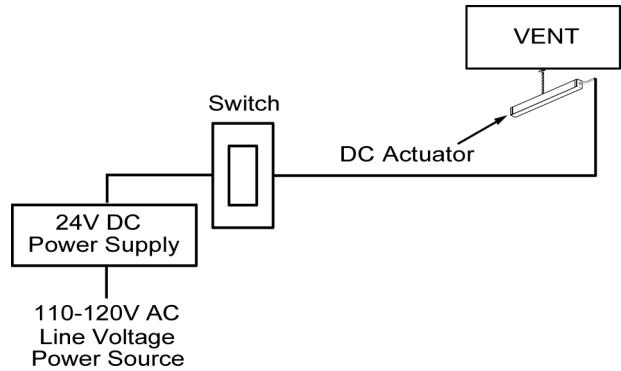

Example 2: Multiple actuator operation

For product specs (such as volt limits) see FFI Data Sheets.

**AC Actuator Group**

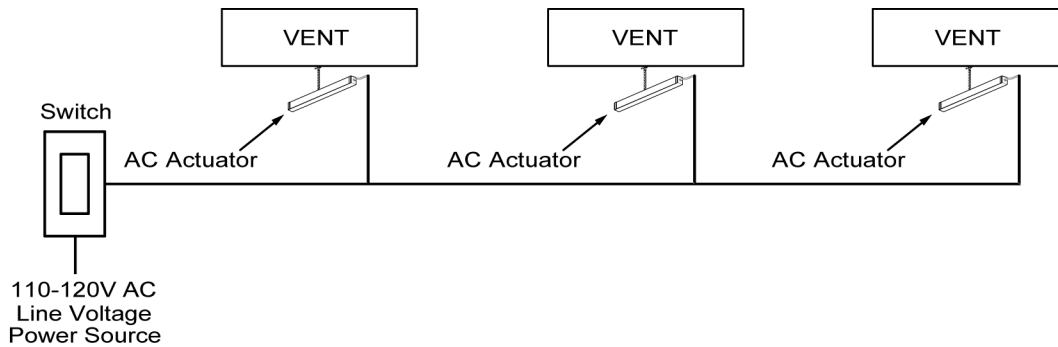

**DC Actuator Group**

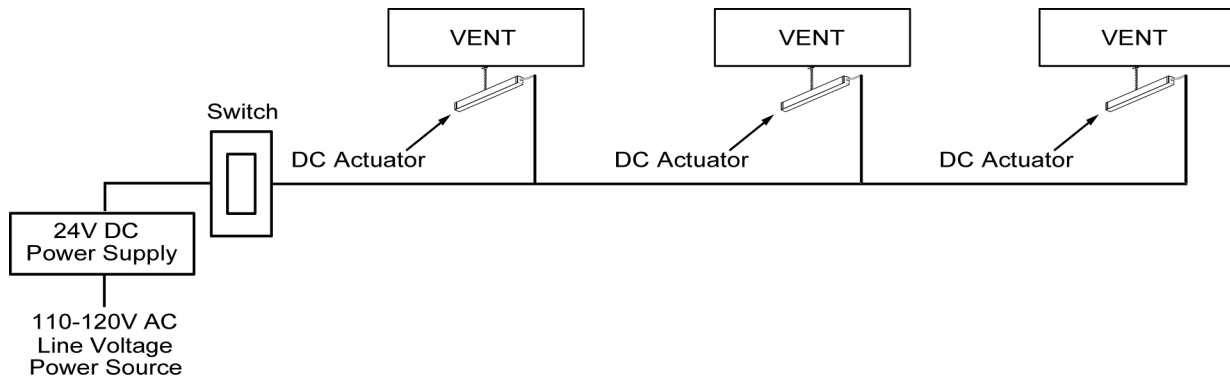

For details visit the [Actuators/Motors page](#), see Data Sheets, and contact FFI Customer Service for Installation Guides and CAD drawings.

FOR REFERENCE ONLY - NOT PROJECT SPECIFIC

## Example 3: Multiple actuators with a control panel

For product specs (such as volt limits) see FFI Data Sheets.

### AC Actuator Groups

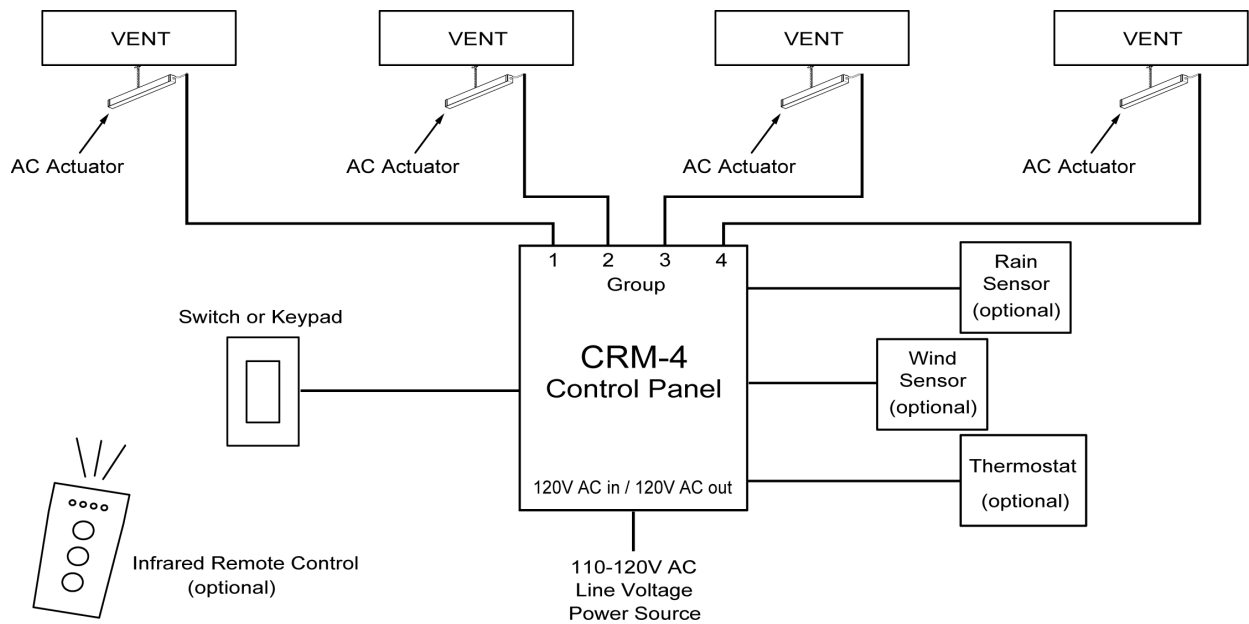

### DC Actuator Groups

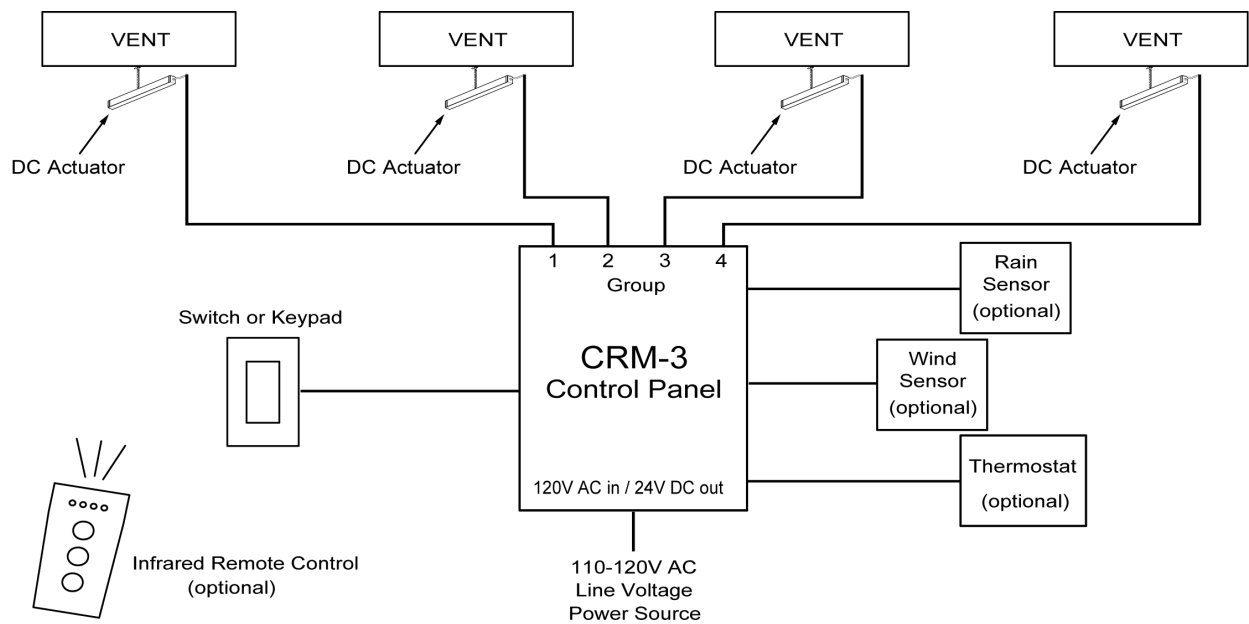

For details visit the [Actuators/Motors page](#), see Data Sheets, and contact FFI Customer Service for Installation Guides and CAD drawings.

FOR REFERENCE ONLY - NOT PROJECT SPECIFIC

### Example 4: Projects with Building Management Systems

For DC actuators only; AC actuators cannot connect to Building Management Systems.

For product specs (such as volt limits) see FFI Data Sheets.

### DC Actuator Group

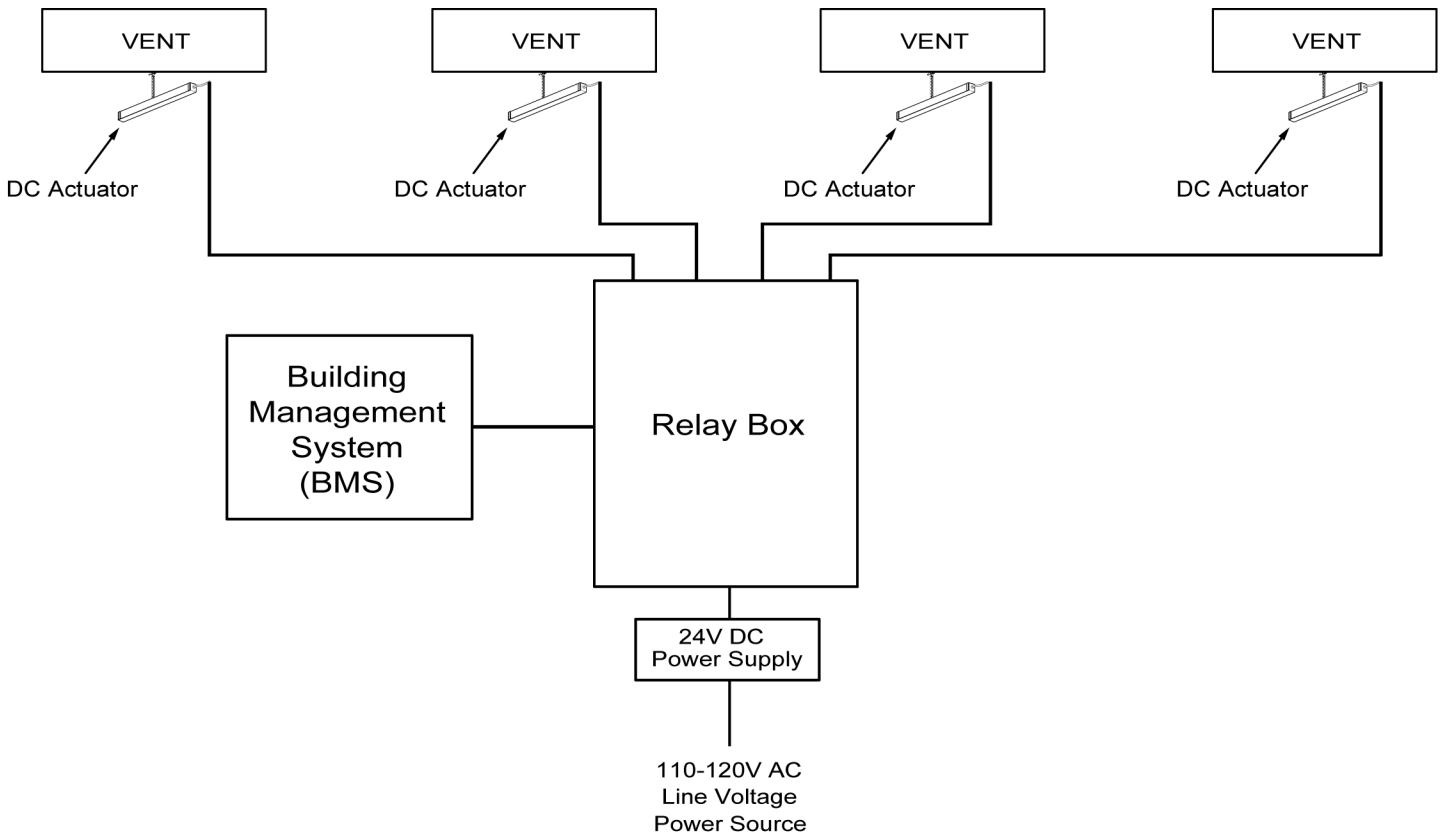

For details visit the [Actuators/Motors page](#), see Data Sheets, and contact FFI Customer Service for Installation Guides and CAD drawings.